

Epsilon Rev

6÷33 kW



General

High efficiency, compact air/water chiller range

Configurations

/LN: version with muffler

Optional hydronic module

Strengths

- ▶ Compatible with Ecodesign
- ▶ Compact dimensions
- ▶ High energy efficiency (EER up to 3.36)
- ▶ Flexible installation to comply with various installation requirements
- ▶ Standardly supplied with EC fans (specific sizes only)

Epsilon Rev

Product description	3
Description of accessories	5
Refrigerant	5
Refrigerant circuit accessories	5
Hydraulic circuit accessories	5
Fan accessories	5
Other accessories	8
Technical specifications	9
Ecodesign	10
Electrical specifications	14
Hydraulic modules	15
Pump data	16
User-side exchanger flow rate fields	17
Operating limits	18
Noise levels	19
Installation advice	20
Water characteristics	20
Glycol mixtures	20
Minimum water content in the system	21
Installation site	22
Installations that require the use of treated coils	23
Aeraulic head losses and options available for the ventilating section	24
Dimensional diagrams	25



Epsilon Rev

PRODUCT DESCRIPTION

High efficiency, compact air/water chiller range

BODY

The structure of the unit is made of galvanized sheet-iron coated with polyester powder in RAL 5017/7035 at 180°C, which makes it highly resistant to weather conditions.

REFRIGERANT

The unit is charged with refrigerant R410A, with GWP=2088 (value at 100 years).

COMPRESSORS

Hermetic scroll compressor, complete with thermal overload protection included in the electric motor windings, and rubber vibration damping supports

SOURCE-SIDE HEAT EXCHANGER

It consists of a coil with copper tubes and aluminium fins having a large exchange surface with fin pitch sized to maximize heat exchange and to reduce the noise impact. A wire mesh is fitted to protect the finned pack.

For installations within a kilometre of the coast, the use of Cu/Al coils with anti-corrosion treatment is strongly recommended.

FANS

Axial flow fans directly coupled to the 6-pin electric motor featuring an external rotor, protection level IP56. Each fan is housed in shaped nozzles and includes an accident-prevention grid, pursuant to standard UNI EN 294.

Units from size 6 through 18 fit fans from the EC series. Sizes 21 through 37 feature AC fans instead. The fan speed regulator accessory is supplied standardly with the base unit.

USER-SIDE HEAT EXCHANGER

The heat exchanger is made of braze-welded stainless steel AISI 316 plates and it is insulated with a shell of closed-cell foam material that reduces heat losses and prevents the formation of condensate.

The heat exchanger is provided with a temperature probe for freeze protection, a probe for measuring the temperature of the input and output water and a paddle flow switch that is standardly supplied with it.

REFRIGERANT CIRCUIT

Each refrigerant circuit comprises:

- charging valve
- liquid sight glass
- replaceable solid cartridge dehydrator filter
- thermostatic expansion valve with pressure equalization
- pressure transducer
- high and low pressure switches
- safety valve (with the exception of sizes 6, 8 and 10)

ELECTRICAL CONTROL PANEL

The electrical control panel is supplied with a master disconnect switch, a protection for the auxiliary power circuits, a compressor contactor and an electronic controller for unit registration featuring an interface display that is used to view and to set the machine parameters.

The electrical control panel comprises:

- a master disconnect switch;
- automatic circuit breakers to protect the auxiliary and power circuits (sizes 6, 8 and 10);
- a master disconnect switch and fuses to protect the auxiliary and power circuits (sizes 14 to 37);
- a compressor contactor;
- a fan speed regulator for condensate control;
- pump relays or a motor protector and circuit breaker (sizes 14 through 37, version ST1P or ST1PS);
- general alarm potential free contacts.
- The electronic controller is designed for management of the following functions:
 - inlet control for water temperature regulation;
 - freeze protection;
 - compressor time setting;
 - high pressure alert management (in many cases this is useful to prevent the unit from stopping);
 - alarm signals;
 - alarm resetting;
 - self-adjusting control to enable optimal operation even when the water level in the system is low;
 - digital input for external ON-OFF switching.
- The display shows the following parameters:
 - output water temperature;
 - condensation temperature;
 - temperature and differential setpoints;
 - alarms description.

The unit power voltage is 230V/1~/50Hz for sizes 6 and 8, and 400V/3N~/50Hz for sizes 10 through 37.

CONTROLS AND SAFETY DEVICES

All the units are fitted with the following control and safety components:

- Anti-freeze probe causing anti-freeze alarm to trigger (automatic resetting at short intervals)
- High pressure switch (with manual reset)
- Low pressure switch (with automatic reset and limited interventions)
- Mechanical vane type flow switch included in the standard supply
- Condensation pressure control by means of speed regulator for operation at low external temperatures
- High pressure safety valve (with the exception of sizes 6, 8 and 10)
- Protection against compressor overtemperature

TESTING

All the units are factory-tested and supplied complete with oil and refrigerant.

OPTIONS

/LN: low noise unit

The unit featuring the /LN option requires that the compressor be covered with a fully noise-proof shroud made of noise absorbing and self-extinguishing material in expanded polyurethane with a density equal to 30 kg/m³ and a thickness of 13 mm on the compressor side and 5 mm on the sheath side.

A rubber, 2 mm thick noise-insulating sheet is interposed between the two layers of expanded polyurethane.

Max. total thickness 20mm

HYDRAULIC MODULES

1P

Unit with pump

The unit includes:

- a circulator (sizes 6 through 18) or a circulation pump (sizes 21 through 37);
- Expansion vessel
- a water drain valve from the hydraulic circuit;
- a safety valve set to 6 bar, which corresponds to the maximum allowable operating pressure.

1PS

Unit with pump and tank

In addition to the components of the /ST 1P unit, this unit includes: an inertial, insulated accumulation tank.

DESCRIPTION OF ACCESSORIES

Refrigerant

R410 R410A

The unit is charged with refrigerant R410A, with GWP=2088 (value at 100 years).

Refrigerant circuit accessories

VS Liquid line solenoid valve

This accessory prevents refrigerant migration that could damage the compressor on starting.

VTE Electronic expansion valve

The use of this component is particularly advisable on units operating in very variable heat load or operating mode conditions, as in the case of joint management of air conditioning and high temperature water production. The use of an electronic thermostatic valve allows you to:

- maximize heat exchange at the evaporator
- minimize response times to changes in load and operating conditions
- optimize control of overheating
- ensure maximum energy efficiency

BK Brine Kit

This accessory is compulsory if a water temperature set point lower than or equal to +3°C is used (if the unit is provided with double set point or variable set point, the lower set point is considered).

The accessory consists of increased insulation and suitable sizing and calibration of some components.

The inlet and outlet temperatures of the user-side exchanger must be given on ordering to allow correct setting of the alarm parameters and verification of the sizing of the expansion valve.

The cooling set point can then be changed by the customer in an interval that, compared to the set point given on ordering, ranges from -1K up to the allowed limit temperature.

The unit will be optimized to work at the set point temperature given on ordering. For different set points, the cooling capacity provided and the level of efficiency of the machine could decrease and move away from these conditions.

Hydraulic circuit accessories

GRPC Filling unit with pressure gauge

This accessory allows automatic filling of the hydraulic system and control of correct operating pressure, which can always be checked on the pressure gauge, and continuously maintains this pressure by replenishing with water if necessary.

RA Antifreeze heater

These are electric heaters inserted on the user-side heat exchanger, on the pumps and in the tank (depending on the configuration of the machine) to prevent damage to the hydraulic components due to ice formation during periods when the machine is stopped.

Based on normal operating conditions and the percentage of glycol in the system, an appropriate "antifreeze alarm" temperature is set in the control. When a temperature that is 1K higher than the antifreeze alarm threshold is detected at the outlet from the exchanger, the pump (if present) and the antifreeze heaters are switched on. If the temperature of the outgoing water reaches the antifreeze alarm threshold, the compressors are stopped, keeping the heaters and the pumps active, and the general alarm contact of the machine is activated.

Fan accessories

VEC EC fans

With this accessory, EC fans, with electronically commutated brushless motor, are used for the ventilating section. These guarantee very high efficiency levels for all working conditions and allow a 15% saving on the power absorbed by each fan working at full capacity.

Also, through a 0-10V analogue signal sent to each fan, the microprocessor carries out condensation/evaporation control by continuous adjustment of the air flow rate as the external air temperature changes, with a further reduction in electrical absorption and noise emission.

For further details, see the dedicated chapter: "Aeraulic load losses and options available for the fan section".

CSP Set point compensation depending on external air temperature

For units fitted with this accessory, the set point of the unit is set so that it can vary between two values, a maximum and a minimum, depending on the external air temperature. The compensation ramp and the maximum and minimum values of the set point can be changed by the user.

Unless otherwise specified in the order, the controller will be set to implement a positive compensation logic according to the temperatures shown in the following diagrams:

Positive compensation

Negative compensation

Chiller

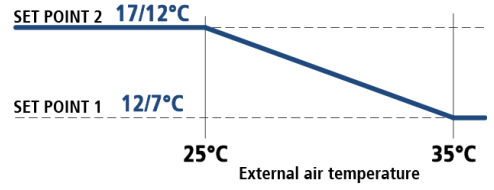
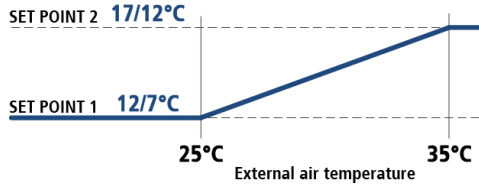

RMMT Maximum and minimum voltage relay

This accessory constantly monitors the voltage value and the unit's power supply phase sequence. If the supply voltage does not fall within the set parameters or there is a phase reversal, an alarm is generated that stops the machine to prevent damage to its main parts

SOFT Electronic soft-starter

The scroll compressors have DOL (Direct On Line) starting and therefore the maximum inrush current I_{MIC} will be 4/5 times its nominal current I_{nom} .

If the unit is equipped with the electronic soft-starter accessory, the starting of each compressor is done with an acceleration ramp that allows the effective value (rms value) of the inrush current of the individual compressor to be lowered.

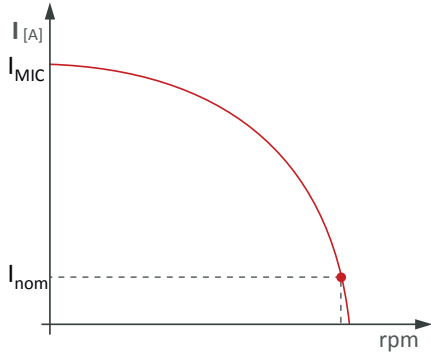

Current trend without accessory Electronic soft-starter

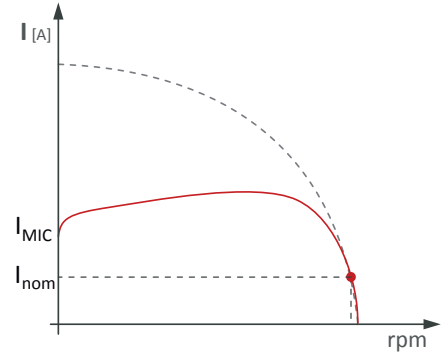

Current trend with accessory Electronic soft-starter

If the unit is equipped with accessory "Power factor correction to $\cos\phi \geq 0.95$ ", this last will be electro-mechanically connected only at the end of the acceleration ramp of the soft-starter.

SQE Heater for electrical control panel

Electric heaters are positioned inside the electrical control panel and these prevent the formation of ice or condensation inside it.

TERM Remote-controlled user terminal panel

This accessory allows the terminal normally situated on the machine to be replicated on a support situated at a distance. It is particularly suitable when the unit is placed in an area that is not easily accessible.

The accessory is supplied loose and is to be installed by the customer at a maximum distance of 120m from the unit. We advise using a cable of the following type: "TECO O.R. FE 2x2xAWG24 SN/ST/PUR".

For this accessory, there is a dedicated serial port.

Other accessories

AG Rubber anti-vibration mounts

These allow you to reduce the vibrations transmitted from the unit to the surface it is standing on. Accessory supplied loose.

ALPR Pre-painted aluminium coil

This accessory uses finned pack coils with copper tubes and aluminium fins pre-painted with an anti-corrosion treatment.

ANTC Coil treated with anti-corrosion paints

The treatment is applied exclusively to finned pack coils with copper tubes and aluminium fins and consists of aluminium passivation and coating with a polyurethane base; a double layer of paint, of which the first passivates the aluminium and acts as primer and the second is a polyurethane based surface coating. The product has high resistance to corrosion and all environmental conditions.

The choice of whether or not to treat the exchanger should be made in relation to the environment in which the unit is to be installed and through observation of other structures and machinery with exposed metal surfaces present in the destination environment.

The cross observation criterion is the most valid method of selection currently available without having to carry out preliminary tests or measurements with instruments. The identified reference environments are:

- marine coastal
- industrial
- urban with a high housing density
- rural

Please note that in cases where different conditions co-exist, even for short periods, the choice must be suitable for preserving the exchanger in the harsher environmental conditions and not in conditions between the worst and best situation.

Particular attention must be given to cases where an environment that is not particularly aggressive becomes aggressive as a consequence of a local and/or temporal concomitant cause such as, for example, due to the presence of a heating flue outlet or an industrial kitchen or a solvent extraction fan in a small craft business.

FW Water filter

To protect the elements of the hydraulic circuit (in particular, the exchangers), there are Y filters that can stop and settle the particles that are normally present in the water flow and would otherwise settle in the more delicate parts of the hydraulic circuit and damage its heat exchange capacity.

Installation of the water filter is mandatory even when it is not supplied as an accessory.

Accessory supplied loose.

GABB Packaging in wooden crate

The unit is protected by a made-to-measure wooden crate. The accessory is mandatory if shipping by container is required.

TECHNICAL SPECIFICATIONS

EPSILON REV

			6	8	10	14	16	18
EPSILON REV								
Cooling (A35; W7)								
Refrigeration capacity	(1)	kW	6,7	7,5	10	13,3	14,8	17,2
Total absorbed power	(1)	kW	2,3	2,6	3,2	4,2	4,7	5,3
EER	(1)		2,9	2,92	3,11	3,12	3,11	3,23
EER energy class (Eurovent)	(1)		C	B	A	A	A	A
Compressors								
Compressors/Circuits		n°/n°	1 / 1	1 / 1	1 / 1	1 / 1	1 / 1	1 / 1
Minimum capacity reduction step		%	0-100	0-100	0-100	0-100	0-100	0-100
Refrigerant charge (CH + CuAl)		kg	2,0	2,2	2,3	3,3	3,2	4,2
Fans								
Type			Axial EC fans	Axial EC fans	Axial EC fans	Axial EC fans	Axial EC fans	Axial EC fans
Quantity		n°	1	1	1	2	2	2
Total air flow rate		m³/h	3900	3900	3600	7800	7800	7200
User-side heat exchanger								
Quantity		n°	1	1	1	1	1	1
Water flow rate (CH) (A35; W7)	(1)	m³/h	1,1	1,3	1,7	2,3	2,5	3
Head loss (CH) (A35; W7)	(1)	kPa	10	10	14	32	25	28
Noise levels								
Sound power level cooling	(3)	dB(A)	65	67	68	70	72	75
Sound pressure level cooling	(4)	dB(A)	34	36	37	39	41	44
Sound power level of vers. LN cooling	(3)	dB(A)	63	65	66	68	70	73
Sound pressure level of vers. LN cooling	(4)	dB(A)	32	34	35	37	39	42
Dimensions and weights**								
Length		mm	925	925	925	925	925	925
Depth		mm	375	375	375	375	375	375
Height		mm	700	700	700	1350	1350	1350
			21	25	28	31	37	
EPSILON REV								
Cooling (A35; W7)								
Refrigeration capacity	(1)	kW	19,3	21,1	24,9	29,6	33,2	
Total absorbed power	(1)	kW	6	6,7	7,4	9,2	10	
EER	(1)		3,18	3,16	3,36	3,22	3,32	
EER energy class (Eurovent)	(1)		A	A	A	A	A	
Compressors								
Compressors/Circuits		n°/n°	1 / 1	1 / 1	1 / 1	1 / 1	1 / 1	
Minimum capacity reduction step		%	0-100	0-100	0-100	0-100	0-100	
Refrigerant charge (CH + CuAl)		kg	3,9	3,8	5,8	5,9	7,2	
Fans								
Type			Axial AC fans	Axial AC fans	Axial AC fans	Axial AC fans	Axial AC fans	
Quantity		n°	2	2	2	2	2	
Total air flow rate		m³/h	14000	14000	13000	18000	17000	
User-side heat exchanger								
Quantity		n°	1	1	1	1	1	
Water flow rate (CH) (A35; W7)	(1)	m³/h	3,3	3,6	4,3	5,1	5,7	
Head loss (CH) (A35; W7)	(1)	kPa	31	27	28	29	29	
Noise levels								
Sound power level cooling	(3)	dB(A)	76	76	76	76	77	
Sound pressure level cooling	(4)	dB(A)	45	45	45	45	46	
Sound power level of vers. LN cooling	(3)	dB(A)	74	74	74	74	75	
Sound pressure level of vers. LN cooling	(4)	dB(A)	43	43	43	43	44	
Dimensions and weights**								
Length		mm	1105	1105	1105	1305	1305	
Depth		mm	675	675	675	695	695	
Height		mm	1385	1385	1385	1585	1585	
Weight in function CH	(5)	kg	212	233	233	367	367	

(1) Outside air temperature 35°C; evaporator inlet-outlet water temperature 12/7°C. Values compliant with standard EN 14511

(3) Unit operating at rated capacity, with no accessories of any kind - external air temperature 35°C and water input/output temperature from/to heat exchanger and user equal to 12/7°C. Values taken by measurements made in accordance with standard ISO 3744 and the Eurovent certification programme, where applicable. Binding values See NOISE LEVELS section.

(4) Values obtained from the sound power level (conditions: note 3), related to a distance of 10 m from the unit in free field with directivity factor Q=2. Non-binding values See NOISE LEVELS section.

(5) The weight refers to the unit without any accessory. The introduction of a few accessories such as copper/aluminum coils, hydraulic modules or the recovery exchangers can lead to weight increased that can exceed 10%. For further details refer to the specific drawing of the selected configuration.

** Basic CH unit without included accessories

ECODESIGN

INTRODUCTION

The Ecodesign/ErP Directive (2009/125/EC) lays down new standards for more efficient energy use.

The Directive contains various regulations; as regards chiller products and heat pumps, the regulations of interest are the following:

- Regulation 2013/813, for small heat pumps ($P_{\text{design}} \leq 400$ kW)
- Regulation 2016/2281, for chillers and heat pumps with $P_{\text{design}} > 400$ kW
- Regulation 2013/811, for heat pumps with $P_{\text{design}} \leq 70$ kW.

The last-mentioned regulation (2013/811) regards the labelling (Ecolabel certification) of small heat pumps.

The other two regulations (2013/813 and 2016/2281) set seasonal efficiency targets that the products must comply with to be sold and installed in the European Union (essential requirement for CE marking).

These efficiency limits are defined through ratios, which are respectively:

- η_{sh} (SCOP), with reference to regulation 2013/813
- η_{sc} (SEER) for comfort applications and SEPR for process applications, with reference to regulation 2016/2281.

As regards regulation 2016/2281, with effect from 1st January 2021, the required minimum efficiency limit will be raised (Tier 2) from the current threshold (Tier 1).

The figure below schematically illustrates the correspondence between product and reference energy ratio.

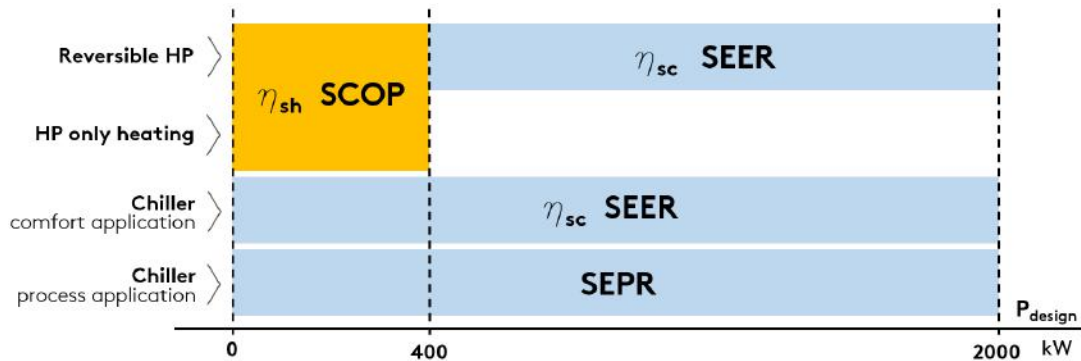

Some notes and clarifications:

For comfort applications, regulation 2016/2281 sets the η_{sc} (SEER) ratio in two different operating conditions:

- SEER calculated with machine inlet/outlet water temperature of 12/7°C (low temperature application),
- SEER calculated with machine inlet/outlet water temperature of 23/18°C (medium temperature application).

The minimum efficiency requirement is the same, but can be met at condition 12/7°C or at condition 23/18°C, depending on the application envisaged for the machine.

Regulation 2013/813 distinguishes two different types: at low temperature and at medium temperature.

The following refer to the application at low temperature: (low temperature application) all heat pumps whose maximum delivery temperature for heating purposes is lower than 52°C with source at temperature of -7°C and -8°C wet bulb (air-water unit) or inlet 10°C (water-water unit), at the reference design conditions for an average climate. For these, the efficiency ratio is "low temperature application" (outlet water temperature 35°C).

For all the other heat pumps, the efficiency ratio is related to "medium temperature application" (outlet water temperature 55°C).

The ratios must be calculated according to the reference European heating season in average climatic conditions.

The minimum efficiency requirements set by the regulations are indicated below.

REGULATION 2016/2281, comfort application

TYPE OF UNIT		MINIMUM REQUIREMENT			
		Tier 1		Tier 2 (2021)	
SOURCE	P _{design}	η_{sc} [%]	SEER	η_{sc} [%]	SEER
air	< 400kW	149	3,8	161	4,1
air	\geq 400kW	161	4,1	179	4,55
water	< 400kW	196	5,1	200	5,2
water	\geq 400kW and < 1500kW	227	5,875	252	6,5
water	\geq 1500kW	245	6,325	272	7

REGULATION 2016/2281, process application

TYPE OF UNIT		MINIMUM REQUIREMENT	
		Tier 1	Tier 2 (2021)
SOURCE	P _{design}	SEPR	SEPR
air	< 400kW	4,5	5
air	\geq 400kW	5	5,5
water	< 400kW	6,5	7
water	\geq 400kW and < 1500kW	7,5	8
water	\geq 1500kW	8	8,5

REGULATION 2013/813

SOURCE	APPLICATION	MINIMUM REQUIREMENT	
		η_{sh} [%]	SCOP
air	low temperature application	125	3,2
water	low temperature application	125	3,325
air	medium temperature application	110	2,825
water	medium temperature application	110	2,95

The conformity of the product must be checked according to the type of application, whether comfort or process, and at the required outlet water temperature.

The two schematic tables below, respectively for comfort application and for process application, indicate the reference of the required conformity according to the type of product and the set point temperature (reference to regulations 2016/2281 and 2013/813).

Important note: for mixed comfort and process applications, the reference application for conformity is the comfort application.

COMFORT APPLICATION

PRODUCT	OUTLET WATER TEMPERATURE	COMPLIANCE INDEX	REGULATION
Chiller	< 18°C	SEER/η _{sc} low temperature application	2016/2281
	≥ 18°C	SEER/η _{sc} medium temperature application	2016/2281
Heat pumps (reversible and only heating) P_{design} ≤ 400kW		SCOP/η _{sh}	2013/813
Reversible heat pumps P_{design} > 400kW	< 18°C	SEER/η _{sc} low temperature application	2016/2281
	≥ 18°C	SEER/η _{sc} medium temperature application	2016/2281
Heat pumps only heating P_{design} > 400kW		-	-

- = exemption from Ecodesign

PROCESS APPLICATION

PRODUCT	OUTLET WATER TEMPERATURE	COMPLIANCE INDEX	REGULATION
Chiller	≥ +2°C , ≤ 12°C	SEPR	2016/2281
	> 12°C	-	-
	> -8°C , < +2°C	-	-

- = exemption from Ecodesign

Some specifications and notes follow.

Partly completed machinery

The term partly completed machinery refers to all units without a user-side or source-side heat exchanger, and therefore to all LC, LE, LC/HP and LE/HP versions. Since these are “non-complete” machines, conformity with Ecodesign depends on combination with the remote heat exchanger.

All the partly completed machinery is CE marked and accompanied by a declaration of conformity. Installation in European Union countries is therefore allowed; correct selection and installation of the remote heat exchanger must be ensured, in accordance with the above cases.

EC fans:

The only option that positively affects the performance of the unit, by increasing its seasonal energy efficiency ratio, is the VEC accessory.

A unit equipped with EC fans has a higher SEER (η_{sc}) than the configuration with standard fans.

EPSILON REV RANGE

Regulation 2016/2281 applies specifically to the Epsilon Rev range.

The tables below give information on the conformity of the units and the seasonal energy performance ratios with regard to the reference regulation.

EPSILON REV

			6	8	10	14	16	18
REGULATION 2016/2281								
Pdesign	(1)	kW	6,7	7,5	10	13,3	14,8	17,2
Compliance 12/7								
Compliance	(1)		Y	Y	Y	Y	Y	Y
η_{sc}	(1)	%	149	151	149	149	149	149
SEER	(1)		3,8	3,84	3,8	3,81	3,81	3,8
Compliance Tier 2 (2021)	(1)		N	N	N	N	N	N
Compliance 23/18								
Compliance	(2)		Y	Y	Y	Y	Y	Y
η_{sc}	(2)	%	-	-	-	-	-	-
SEER	(2)		-	-	-	-	-	-
Compliance SEPR								
Compliance	(3)		Y	Y	Y	Y	Y	Y
SEPR	(3)		4,91	4,97	4,94	5,30	5,23	5,06
			21	25	28	31	37	
REGULATION 2016/2281								
Pdesign	(1)	kW	19,3	21,1	24,9	29,6	33,2	
Compliance 12/7								
Compliance	(1)		Y	Y	Y	Y	Y	
η_{sc}	(1)	%	150	149	150	150	150	
SEER	(1)		3,82	3,82	3,81	3,82	3,83	
Compliance Tier 2 (2021)	(1)		N	N	N	N	N	
Compliance 23/18								
Compliance	(2)		Y	Y	Y	Y	Y	
η_{sc}	(2)	%	-	-	-	-	-	
SEER	(2)		-	-	-	-	-	
Compliance SEPR								
Compliance	(3)		Y	Y	Y	Y	Y	
SEPR	(3)		5,09	5,06	5,10	5,03	5,10	

Y = unit in compliance with Ecodesign at the indicated condition.

N = unit not in compliance with Ecodesign at the indicated condition: it can be installed only in non-EU countries.

- = value not necessary: conformity is already provided at the most restrictive condition (1).

- (1) User-side heat exchanger water inlet/outlet temperature 12/7°C (low temperature application), with reference to regulation 2016/2281 and standard EN 14825.
- (2) User-side heat exchanger water inlet/outlet temperature 23/18°C (medium temperature application), with reference to regulation 2016/2281 and standard EN 14825.
- (3) User-side heat exchanger water inlet/outlet temperature 12/7°C, with reference to regulation 2016/2281 and norm EN 14825.

ELECTRICAL SPECIFICATIONS

EPSILON REV

			6	8	10	14	16	18
General electrical specifications								
Max. absorbed power (FLI)	(1)	kW	3,1	3,8	4,4	6,1	6,2	7,4
Max. absorbed current (FLA)	(1)	A	17	20	9	12	13	16
Maximum inrush current (MIC)	(3)	A	62	83	49	66	65	75
Power supply			230/1~/50			400/3N~/50		
Power supply for auxiliary circuits			230/1~/50					
Electrical specifications for fans								
Rated power of AC fan		n° x kW	-	-	-	-	-	-
Rated current of AC fan		n° x A	-	-	-	-	-	-
Rated power of EC fan		n° x kW	1 x 0,11	1 x 0,11	1 x 0,11	2 x 0,11	2 x 0,11	2 x 0,11
Rated current of EC fan		n° x A	1 x 0,95	1 x 0,95	1 x 0,95	2 x 0,95	2 x 0,95	2 x 0,95
			21	25	28	31	37	
General electrical specifications								
Max. absorbed power (FLI)	(1)	kW	9	9,8	10,9	13	14,7	
Max. absorbed current (FLA)	(1)	A	19	20	25	27	30	
Maximum inrush current (MIC)	(3)	A	105	99	115	123	123	
Power supply			400/3N~/50					
Power supply for auxiliary circuits			230/1~/50					
Electrical specifications for fans								
Rated power of AC fan		n° x kW	2 x 0,4	2 x 0,4	2 x 0,4	2 x 0,6	2 x 0,6	
Rated current of AC fan		n° x A	2 x 1,8	2 x 1,8	2 x 1,8	2 x 2,6	2 x 2,6	
Rated power of EC fan		n° x kW	2 x 0,73	2 x 0,73	2 x 0,73	2 x 0,825	2 x 0,825	
Rated current of EC fan		n° x A	2 x 3,2	2 x 3,2	2 x 3,2	2 x 1,4	2 x 1,4	

- (1) Data regarding the unit without accessories working in maximum power absorption conditions
- (2) Datum related to the unit without accessories working in standard conditions (A35°C; W12/7°C)
- (3) Maximum effective RMS value of the current when the last compressor starts (FLA of the entire unit - FLA of the largest compressor + LRA of the largest compressor)
- (5) These values are determined for cables with operating temperature of 40°C, EPR insulation and a line with a maximum length of 50m. The line section must be determined by a qualified technician based on the protection devices, the length of the line, the type of cable used and the type of installation.
- (6) The correct line protection part must be determined by a qualified technician based on the length of the line, the type of cable used and the type of installation.

HYDRAULIC MODULES

EPSILON REV

			6	8	10	14	16	18
Volume of the expansion vessel		l	2	2	2	2	2	2
Volume of the buffer tank		l	40	40	40	70	70	70
Standard pumps								
Pump model			PARA RS 30/7.5-RKA- FSM-180-12	PARA RS 30/7.5-RKA- FSM-180-12	PARA RS 30/7.5-RKA- FSM-180-12	YONOS PARA HF 30/10	YONOS PARA HF 30/10	YONOS PARA HF 30/10
Available head	(1)	kPa	59	59	56	60	63	61
			21	25	28	31	37	
Volume of the expansion vessel		l	5	5	5	5	5	5
Volume of the buffer tank		l	110	110	110	140	140	140
Standard pumps								
Pump model			5HM02P05M5H- QQEXD	5HM02P05M5H- QQEXD	5HM02P05M5H- QQEXD	5HM02P04T5RQQEXD	CIE 120/4	
Available head	(1)	kPa	149	148	135	119	162	

(1) External air temperature 35°C, user-side heat exchanger water inlet/outlet temperature 12/7°C. Values in accordance with EN 14511.

PUMP DATA

Model	Rated power	Rated current	Qmin	Qmax
	kW	A	m ³ /h	m ³ /h
C1	0,08	0,60	0	4
C1	0,08	0,6	0	4
C1	0,08	0,6	0	4
C2	0,19	1,3	0	8,4
C2	0,19	1,3	0	8,4
C2	0,19	1,3	0	8,4
P3	0,6	2,79	2,4	7,2
P3	0,61	2,79	2,4	7,2
P3	0,62	2,79	2,4	7,2
P4	0,63	2,48	2,4	7,2
P5	0,9	3,64	3,6	9,6

USER-SIDE EXCHANGER FLOW RATE FIELDS

The units are sized and optimized for the following nominal conditions: external air 35°C, inlet-outlet of the user-side exchanger 12/7°C.

The units can work at design conditions different from nominal conditions, provided that:

- the design condition falls within the operating limits specified below
- the flow rate at design conditions (that is, of the specific application) must always come within the allowed flow rate ranges specified below. If the design conditions require a water flow rate that does not come within the allowed operating range, you must contact our sales department that will identify the most suitable solution for the specific application.

EPSILON REV

	Qmin	Qmax
	m ³ /h	m ³ /h
6	0,57	1,72
8	0,64	1,93
10	0,86	2,57
14	1,14	3,43
16	1,27	3,82
18	1,48	4,43
21	1,66	4,97
25	1,81	5,43
28	2,15	6,44
31	2,55	7,64
37	2,86	8,57

OPERATING LIMITS

COOLING

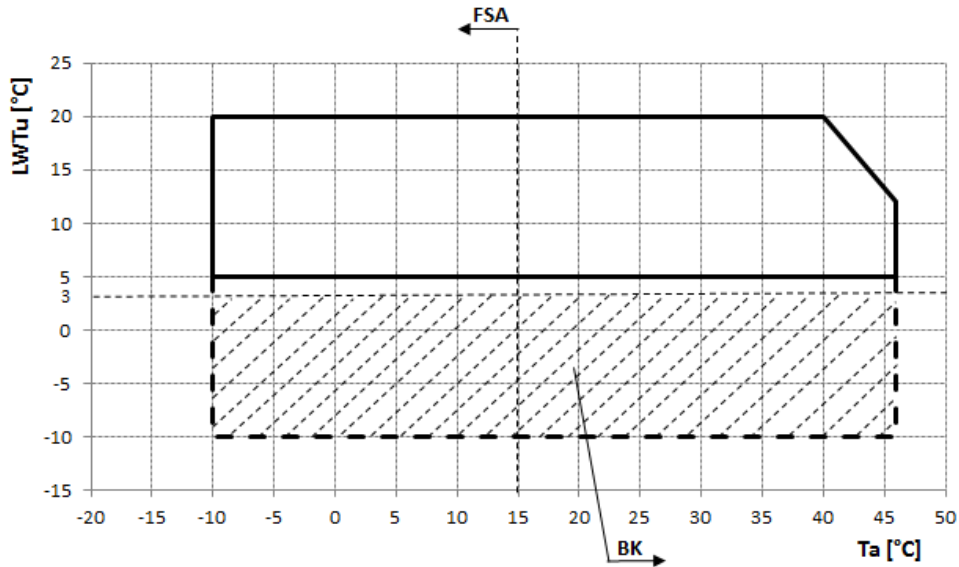

Ta: external air temperature

LWTu: water outlet temperature from the user-side heat exchanger

BK: For LWTu below +3°C, it is mandatory to fit the "Brine Kit" accessory

FSA: Work in the area indicated by the arrow requires that "EC Fans" accessory be fitted, where applicable.

For LWTu below +5°C, it is compulsory to use suitable percentages of antifreeze additives (glycols) to prevent ice formation in the exchanger.

The inlet and outlet temperatures of the user-side exchanger must be given on ordering to allow correct setting of the alarm parameters and verification of the sizing of the expansion valve.

The cooling set point can then be changed by the customer in an interval that, compared to the set point given on ordering, ranges from -1K up to the maximum temperature allowed by the above-stated operating limits.

The unit will be optimized to work at the set point temperatures given on ordering. For different set points, the cooling capacity provided and the level of efficiency of the machine could decrease and move away from these conditions.

NOISE LEVELS

EPSILON REV

	Octave bands [dB]																Total [dB(A)]	
	63 Hz		125 Hz		250 Hz		500 Hz		1000 Hz		2000 Hz		4000 Hz		8000 Hz		Lw_tot	Lp_tot
	Lw	Lp	Lw	Lp	Lw	Lp	Lw	Lp	Lw	Lp	Lw	Lp	Lw	Lp	Lw	Lp		
6	69	38	69	38	68	37	64	33	58	27	54	23	47	16	40	9	65	34
8	70	39	70	39	69	38	66	35	59	28	56	25	50	19	42	11	67	36
10	74	43	71	40	72	41	66	35	62	31	58	27	51	20	44	13	68	37
14	74	43	74	43	72	41	69	38	64	33	58	27	53	22	43	12	70	39
16	77	46	76	45	76	45	70	40	65	34	61	30	56	25	46	15	72	41
18	80	49	79	48	79	48	73	42	68	37	64	33	57	26	50	19	75	44
21	81	50	79	48	80	49	74	43	70	39	65	34	57	26	51	20	76	45
25	81	50	79	48	79	48	75	44	67	36	64	33	59	28	50	19	76	45
28	81	50	80	49	79	48	75	44	68	37	65	34	60	29	51	20	76	45
31	81	49	79	47	80	48	74	42	69	37	65	33	58	26	51	19	76	45
37	83	51	82	50	80	48	76	45	70	38	66	34	60	28	53	21	77	46

EPSILON REV /LN

	Octave bands [dB]																Total [dB(A)]	
	63 Hz		125 Hz		250 Hz		500 Hz		1000 Hz		2000 Hz		4000 Hz		8000 Hz		Lw_tot	Lp_tot
	Lw	Lp	Lw	Lp	Lw	Lp	Lw	Lp	Lw	Lp	Lw	Lp	Lw	Lp	Lw	Lp		
6	67	36	67	36	66	35	62	31	56	25	52	21	45	14	38	7	63	32
8	68	37	68	37	67	36	64	33	57	26	54	23	48	17	40	9	65	34
10	72	41	69	38	70	39	64	33	60	29	56	25	49	18	42	11	66	35
14	72	41	72	41	70	39	67	36	62	31	56	25	51	20	41	10	68	37
16	75	44	74	43	74	43	68	38	63	32	59	28	54	23	44	13	70	39
18	78	47	77	46	77	46	71	40	66	35	62	31	55	24	48	17	73	42
21	79	48	77	46	78	47	72	41	68	37	63	32	55	24	49	18	74	43
25	79	48	77	46	77	46	73	42	65	34	62	31	57	26	48	17	74	43
28	79	48	78	47	77	46	73	42	66	35	63	32	58	27	49	18	74	43
31	79	47	77	45	78	46	72	40	67	35	63	31	56	24	49	17	74	43
37	81	49	80	48	78	46	74	43	68	36	64	32	58	26	51	19	75	44

The acoustic data are related to standard conditions (source on a reflective surface in free field) in referable and reproducible operating conditions. The environment and the installation conditions, as well as the operating modes, can alter the sound emissions. All data with the exception of Lw_tot are provided for illustrative purposes only and can not be used for forecasting purposes or for the verification of binding limits.

Reference conditions: external air temperature 35°C; water input/output temperature from/to heat exchanger and user 12-7°C; unit operating at rated capacity, without any accessory

Lw: Values taken by measurements made in accordance with standard ISO 3744 and the Eurovent certification programme, where applicable Lw_tot is the only binding value.

Lp: Binding values starting from noise power levels referred to a distance of 10 m from the unit; source installed on a reflective surface and in ideal free field conditions with directivity factor Q=2. No Lp value is binding.

Noise data refer to the standard conditions illustrated above, in reference and reproducible operating conditions. All data, excluding Lw_tot, are provided for the sake of exemplification and must not therefore be used for forecasting purposes or for the verification of mandatory limits. With special reference to noise emissions, the Manufacturer takes liability for their conformity, limited to the declared Lw_tot value. Any and all other Manufacturer's liability for the impact of such emissions in relation to the location of the machine and other conditions related to machine installation is excluded. Any assessment concerning these conditions falls within the area of competence of the plant designer and/or the fitter.

INSTALLATION ADVICE

The units described in this document are, by nature, strongly affected by the characteristics of the system, the working conditions and the installation site.

Remember that the unit must be installed by a qualified and skilled technician, and in compliance with the national legislation in force in the destination country.

The installation must be done in such a way that it will be possible to carry out all routine and non-routine maintenance operations.

Before starting any work, you must carefully read the "Installation, operation and maintenance manual" of the machine and do the necessary safety checks to prevent any malfunctioning or hazards.

We give some advice below that will allow you to increase the efficiency and reliability of the unit and therefore of the system into which it is inserted.

Water characteristics

To preserve the life of the exchangers, the water is required to comply with some quality parameters and it is therefore necessary to make sure its values fall within the ranges indicated in the following table:

Total hardness	2,0 ÷ 6,0 °f
Langelier index	- 0,4 ÷ 0,4
pH	7,5 ÷ 8,5
Electrical conductivity	10÷500 µS/cm
Organic elements	-
Hydrogen carbonate (HCO₃⁻)	70 ÷ 300 ppm
Sulphates (SO₄²⁻)	< 50 ppm
Hydrogen carbonate / Sulphates (HCO₃⁻/SO₄²⁻)	> 1
Chlorides (Cl⁻)	< 50 ppm
Nitrates (NO₃⁻)	< 50 ppm
Hydrogen sulphide (H₂S)	< 0,05 ppm
Ammonia (NH₃)	< 0,05 ppm
Sulphites (SO₃⁻), free chlorine (Cl₂)	< 1 ppm
Carbon dioxide (CO₂)	< 5 ppm
Metal cations	< 0,2 ppm
Manganese ions (Mn⁺⁺)	< 0,2 ppm
Iron ions (Fe²⁺ , Fe³⁺)	< 0,2 ppm
Iron + Manganese	< 0,4 ppm
Phosphates (PO₄³⁻)	< 2 ppm
Oxygen	< 0,1 ppm

Installation of water filters on all the hydraulic circuits is obligatory.

The supply of the most suitable filters for the unit can be requested as accessory. In this case, the filters are supplied loose and must be installed by the customer following the instructions given in the installation, operation and maintenance manual.

Glycol mixtures

With temperatures below 5°C, it is mandatory to work with water and anti-freeze mixtures, and also change the safety devices (anti-freeze, etc.), which must be carried out by qualified authorised personnel or by the manufacturer.

Liquid outlet temperature or minimum ambient temperature	°C	0	-5	-10	-15	-20	-25	-30	-35	-40
Freezing point	°C	-5	-10	-15	-20	-25	-30	-35	-40	-45
Ethylene glycol	%	6	22	30	36	41	46	50	53	56
Propylene glycol	%	15	25	33	39	44	48	51	54	57

The quantity of antifreeze should be considered as % on weight

Minimum water content in the system

For correct operation of the unit, it is necessary to ensure a buffering on the system such as to comply with the minimum operating time considering the greater between the minimum OFF time and the minimum ON time. In short, these contribute to limiting the number of times the compressors are switched on per hour and to preventing undesired deviations from the set point of the delivered water temperature.

$$V_{min} = \frac{P_{tot} \cdot 1.000}{N} \cdot \frac{300}{\Delta T \cdot \rho \cdot c_p} + P_{tot} \cdot 0,25$$

where

V_{min} is the minimum water content of the system [l]

P_{tot} is the total cooling capacity of the machine [kW]

N: number of capacity reduction steps

ΔT : differential allowed on the water temperature. Unless otherwise specified, this value is considered to be 2.5K

ρ : density of the heat-carrying fluid. Unless otherwise specified, the density of water is considered

c_p : specific heat of the heat-carrying fluid. Unless otherwise specified, the specific heat of water is considered

Considering the use of water and grouping together some terms, the formula can be re-written as follows:

$$V_{min} = \frac{P_{tot}}{N} \cdot 17,2 + P_{tot} \cdot 0,25$$

N is equal to the number of compressors installed in the unit.

Installation site

To determine the best installation site for the unit and its orientation, you should pay attention to the following points:

- compliance with the clearance spaces indicated in the official dimensional drawing of the unit must be guaranteed so as to ensure accessibility for routine and non-routine maintenance operations
- you should consider the origin of the hydraulic pipes and their diameters because these affect the radiuses of curvature and therefore the spaces needed for installing them
- you should consider the position of the cable inlet on the electrical control panel of the unit as regards the origin of the power supply
- if the installation includes several units side by side, you should consider the position and dimensions of the manifolds of the user-side exchangers and of any recovery exchangers
- if the installation includes several units side by side, you should consider that the minimum distance between units is 3 metres
- you should avoid all obstructions that can limit air circulation to the source-side exchanger or that can cause recirculation between air supply and intake
- you should consider the orientation of the unit to limit, as far as possible, exposure of the source-side exchanger to solar radiation
- if the installation area is particularly windy, the orientation and positioning of the unit must be such as to avoid air recirculation on the coils. If necessary, we advise making windbreak barriers in order to prevent malfunctioning.

Once the best position for the unit has been identified, you must check that the support slab has the following characteristics:

- its dimensions must be proportionate to those of the unit: if possible, longer and wider than the unit by at least 30 cm and 15/20cm higher than the surrounding surface
- it must be able to bear at least 4 times the operating weight of the unit
- it must allow level installation of the unit: although the unit is installed on a horizontal base, make slopes in the support surface to convey rain water or defrost water to drains, wells or in any case to places where it cannot generate an accident hazard due to ice formation.

The units are designed and built to reduce to a minimum the level of vibration transmitted to the ground, but it is in any case advisable to use rubber or spring anti-vibration mounts, which are available as accessory and should be requested when ordering.

The anti-vibration mounts must be fixed on before positioning the unit on the ground.

In the event of installation on roofs or intermediate floors, the pipes must be isolated from the walls and ceilings.

It is advisable to avoid installation in cramped places, to prevent reverberations, reflections, resonances and acoustic interactions with elements outside the unit.

It is essential that any work done to soundproof the unit does not affect its correct installation or correct operation and, in particular, does not reduce the air flow rate to the source-side exchanger.

Installations that require the use of treated coils

If the unit has to be installed in an environment with a particularly aggressive atmosphere, coils with special treatments are available as options.

- pre-painted aluminium coils
- coils with anti-corrosion treatment

A description of the individual accessories is available in the "Description of accessories" section.

The type of coil treatment should be chosen with regard to the environment in which the unit is to be installed, through observation of other structures and machinery with exposed metal surfaces present in the destination environment.

The cross observation criterion is the most valid method of selection currently available without having to carry out preliminary tests or measurements with instruments. The identified reference environments are:

- coastal/marine
- industrial
- urban with a high housing density
- rural

Please note that in cases where different conditions co-exist, even for short periods, the choice must be suitable for preserving the exchanger in the harsher environmental conditions and not in conditions between the worst and best situation.

Particular attention must be given in cases where an environment that is not particularly aggressive becomes aggressive as a consequence of a concomitant cause, for example, the presence of a flue outlet or an extraction fan.

We strongly suggest choosing one of the treatment options if at least one of the points listed below is verified:

- there are obvious signs of corrosion of the exposed metal surfaces in the installation area
- the prevailing winds come from the sea towards the unit
- the environment is industrial with a significant concentration of pollutants
- the environment is urban with a high population density
- the environment is rural with the presence of organic discharges and effluents

In particular, for installations near the coast, the following instructions apply:

for installations between 1 and 20 km from the coast of reversible units or units with Cu/Al coils, we strongly recommend using the accessory "Coil treated with anti-corrosion paints"

for distances within a kilometre of the coast, we strongly recommend using the accessory "Coil treated with anti-corrosion paints" for all units.

To protect the exchangers from corrosion and ensure optimal operation of the unit, we advise following the recommendations given in the user, installation and maintenance manual for cleaning the coils.

Aeraulic head losses and options available for the ventilating section

Units are designed in such way that the fans operate with no discharge head at the rated air flow rate.

If there are obstacles to free air flow, you should consider the additional aeraulic head losses that will cause a reduction of the air flow rate and a consequent deterioration of performance.

The following diagrams show the trend of cooling capacity (P_c), EER, total absorbed power (P_{abs}) and reduction of the maximum external air temperature in chiller operating mode, depending on the aeraulic head losses that the fans will have to overcome.

AC fans (Ø 630)

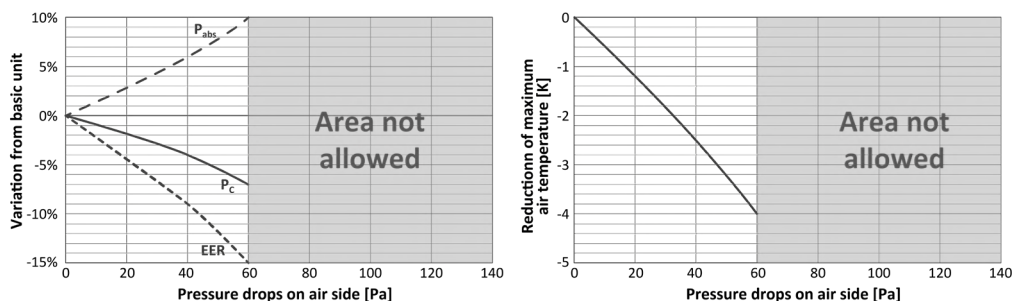

EC fans (Ø 630)

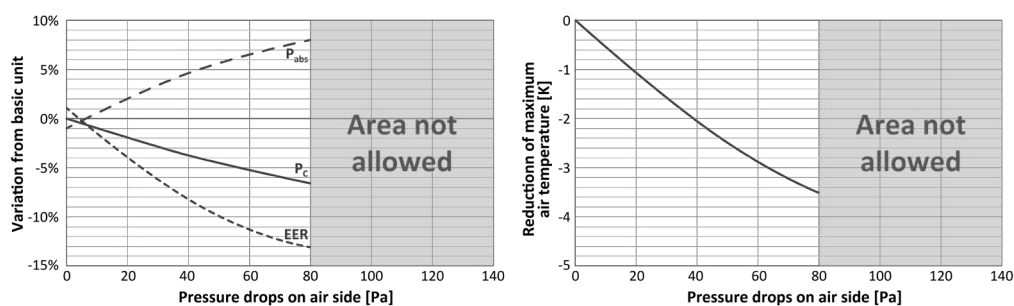

The indicated values are for the standard machine, without accessories, with AC fans and in any case in the absence of air recirculation.

Example: supposing you expect there to be obstacles that will generate an estimated aeraulic head loss of 60Pa. In this case, there are 3 possibilities:

- use the unit with standard AC fans: compared to ideal conditions, the output power will be reduced by about 5.5%, the total absorbed power will increase by about 7.5%, the EER will be reduced by about 12.5% and the maximum allowed external air temperature for operation at 100% will be reduced by about 3.4K compared to the nominal limit
- use the unit with EC fans: compared to the unit with AC fans working in ideal conditions, the output power will be reduced by about 5%, the total absorbed power will increase by about 6.5%, the EER will be reduced by about 11.5% and the maximum allowed external air temperature for operation at 100% will be reduced by about 2.8K compared to the nominal limit

DIMENSIONAL DIAGRAMS

EPSILON REV 6 - 10 /ST 1P

DIM000398A

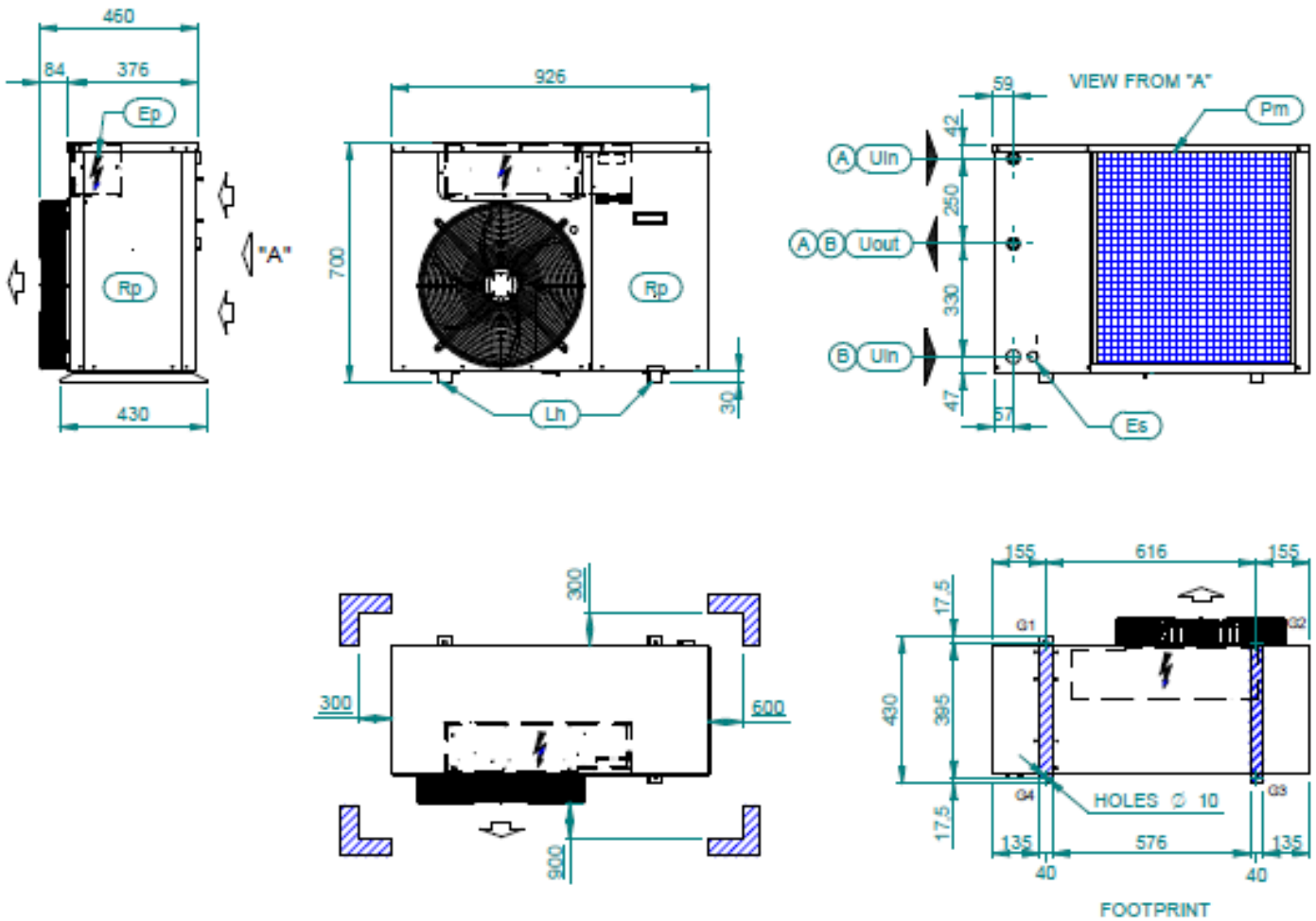

HYDRAULIC CONNECTIONS

- (A) WITHOUT HYDRAULIC MODULE
- (B) HYDRAULIC MODULE ST1P

Uin	Uout
A-B	A-B
G1" M	G1" M

MODEL	WEIGHT(kg)	OPERATING WEIGHT (kg)	G1 (kg)	G2 (kg)	G3 (kg)	G4 (kg)
EPSILON REV 6 CH	99	100	25	9	17	49
EPSILON REV 8 CH	101	102	26	9	17	50
EPSILON REV 10 CH	102	103	26	9	17	51
EPSILON REV 6 CH 1P	108	111	32	10	16	53
EPSILON REV 8 CH 1P	111	114	32	10	17	55
EPSILON REV 10 CH 1P	113	116	33	10	17	56

Note: These drawings are not contractually binding. For the installation design, refer to the specific dimensional drawing available on request.

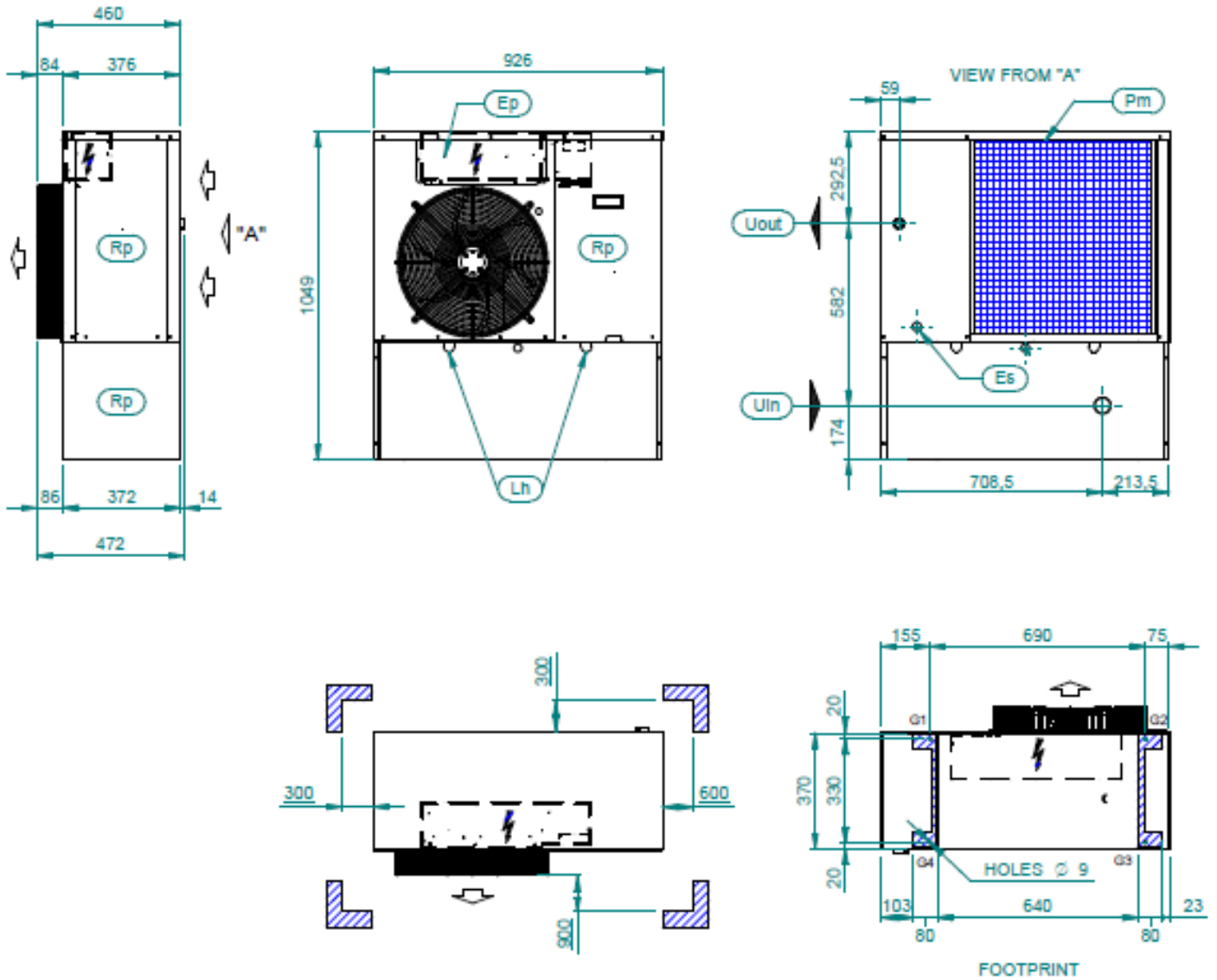

Uin	Uout
G1" F	G1" M

MODEL	WEIGHT(kg)	OPERATING WEIGHT (kg)	G1 (kg)	G2 (kg)	G3 (kg)	G4 (kg)
EPSILON REV 6 CH_1PS	142	214	63	32	40	79
EPSILON REV 8 CH_1PS	151	223	65	31	41	86
EPSILON REV 10 CH_1PS	160	232	67	31	42	92

Note: These drawings are not contractually binding. For the installation design, refer to the specific dimensional drawing available on request.

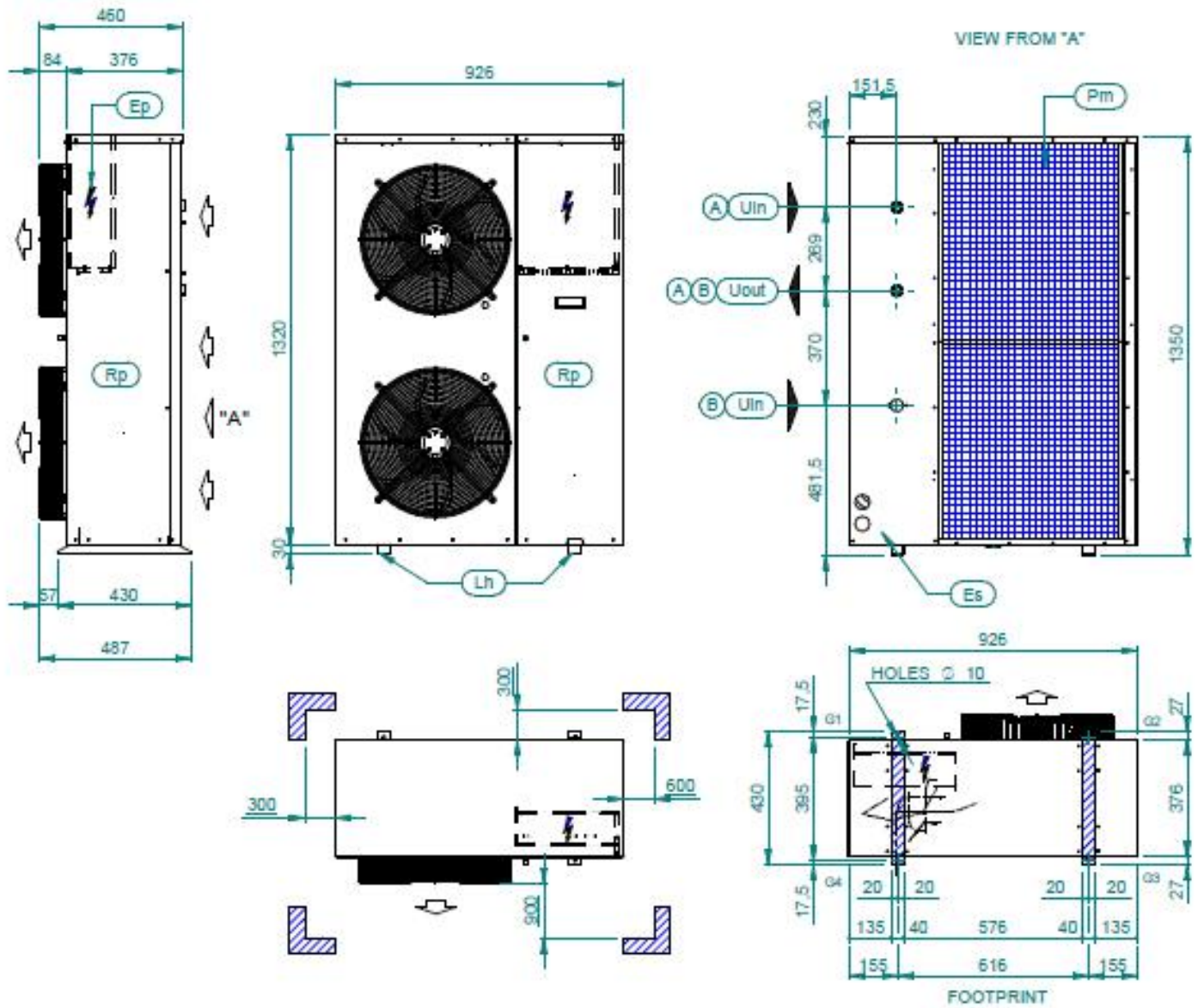

HYDRAULIC CONNECTIONS

- (A) WITHOUT HYDRAULIC MODULE
- (B) HYDRAULIC MODULE ST1P

Uin	Uout
A - B	A - B
G1 * M	G1 * M

MODEL	WEIGHT(kg)	OPERATING WEIGHT (kg)	G1 (kg)	G2 (kg)	G3 (kg)	G4 (kg)
EPSILON REV 14 CH	148	149	36	16	29	68
EPSILON REV 16 CH	150	151	37	16	29	69
EPSILON REV 18 CH	152	153	38	16	29	70
EPSILON REV 14 CH_1P	160	160	44	17	28	71
EPSILON REV 16 CH_1P	172	172	46	17	29	80
EPSILON REV 18 CH_1P	174	174	47	17	29	81

Note: These drawings are not contractually binding. For the installation design, refer to the specific dimensional drawing available on request.

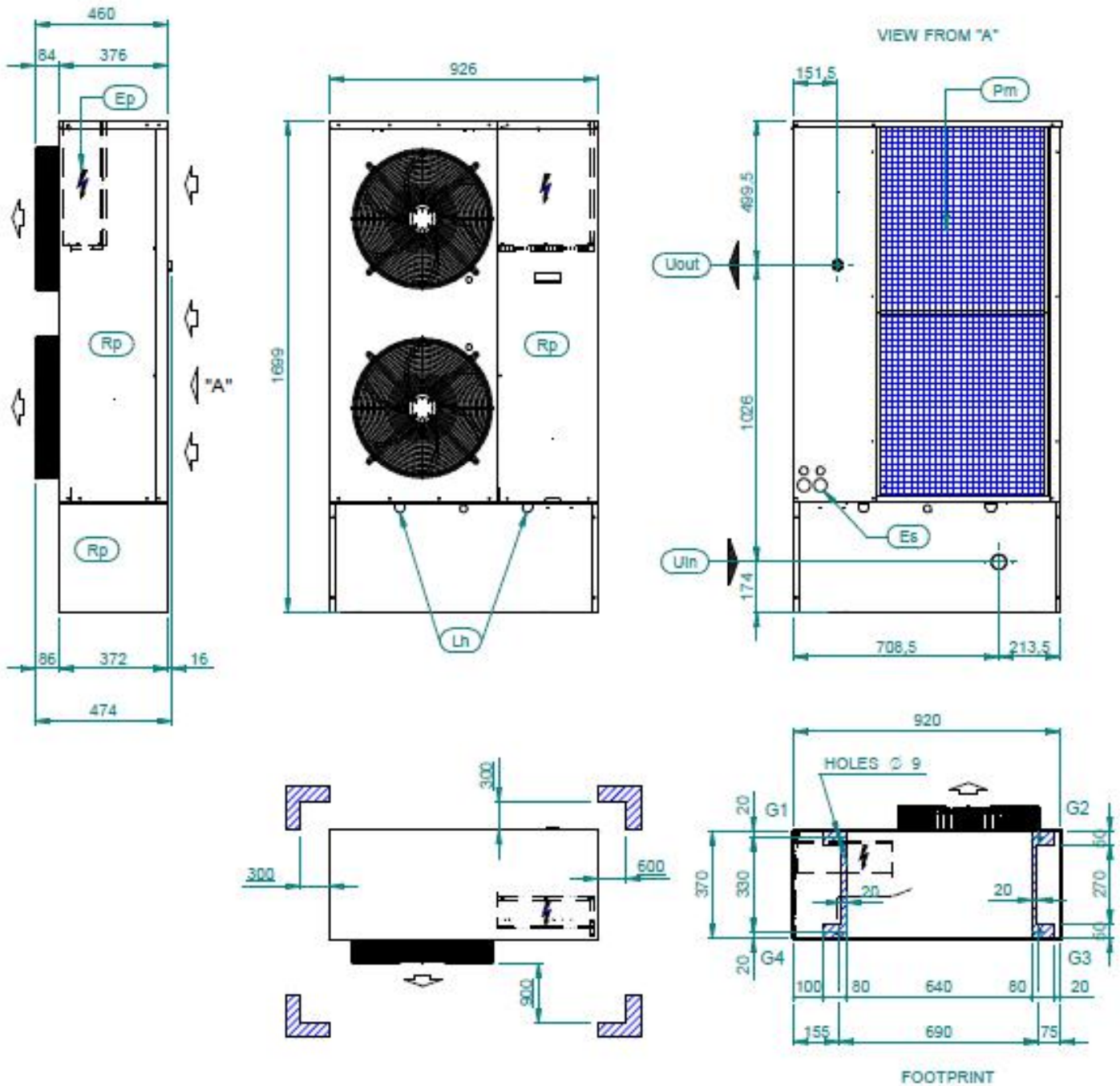

Uin	Uout
G1" F	G1" M

MODEL	WEIGHT(kg)	OPERATING WEIGHT (kg)				
		G1 (kg)	G2 (kg)	G3 (kg)	G4 (kg)	
EPSILON REV 14 CH_1PS	214	287	83	40	53	111
EPSILON REV 16 CH_1PS	216	289	84	40	53	112
EPSILON REV 18 CH_1PS	219	292	85	40	53	114

Note: These drawings are not contractually binding. For the installation design, refer to the specific dimensional drawing available on request.

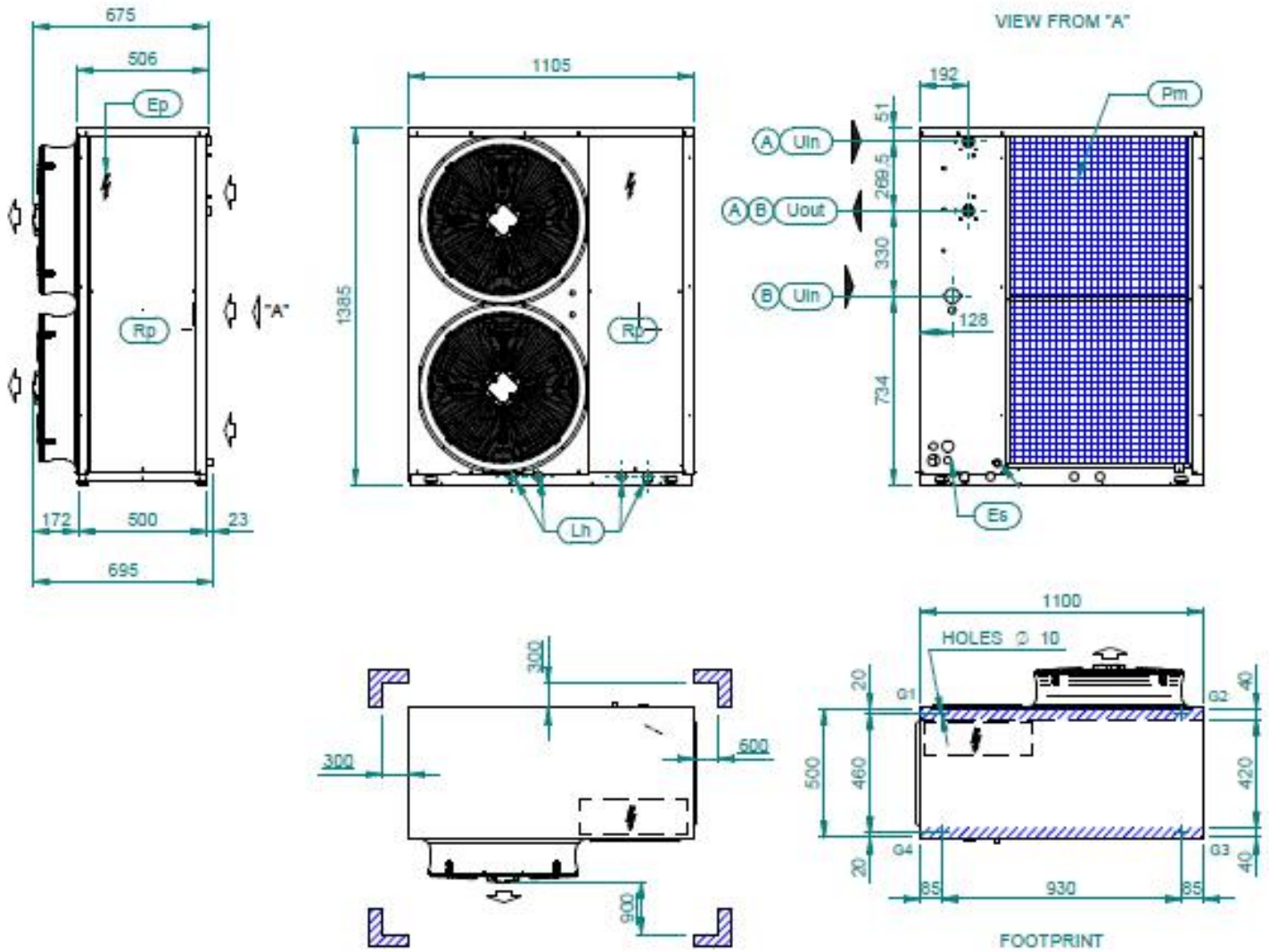

HYDRAULIC CONNECTIONS

- (A) WITHOUT HYDRAULIC MODULE
- (B) HYDRAULIC MODULE ST1P

Uin		Uout
A	B	A - B
1" M	1" 1/4 F	1" M

MODEL	WEIGHT(kg)	OPERATING WEIGHT (kg)				
		G1 (kg)	G2 (kg)	G3 (kg)	G4 (kg)	
EPSILON REV 21 CH	241	242	46	30	66	100
EPSILON REV 25 CH	247	248	53	33	62	100
EPSILON REV 28 CH	251	252	55	34	62	101
EPSILON REV 21 CH_1P	256	259	53	32	66	108
EPSILON REV 25 CH_1P	261	264	60	35	62	107
EPSILON REV 28 CH_1P	265	268	62	35	62	109

Note: These drawings are not contractually binding. For the installation design, refer to the specific dimensional drawing available on request.

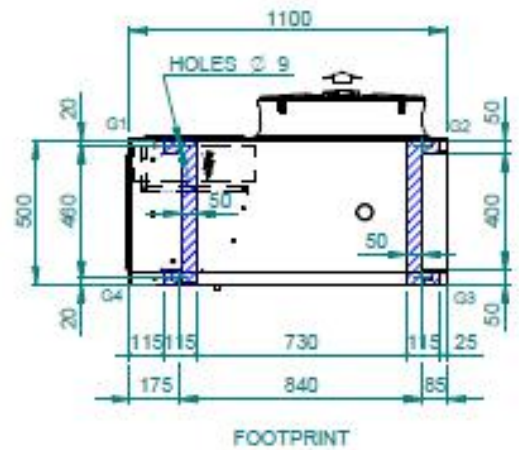
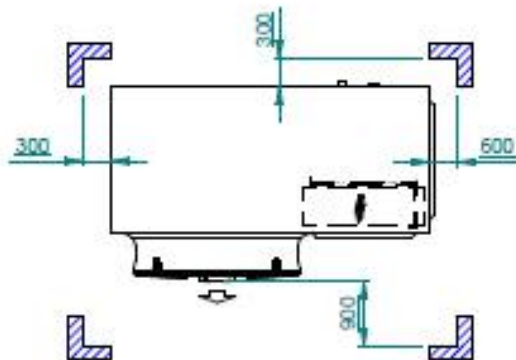
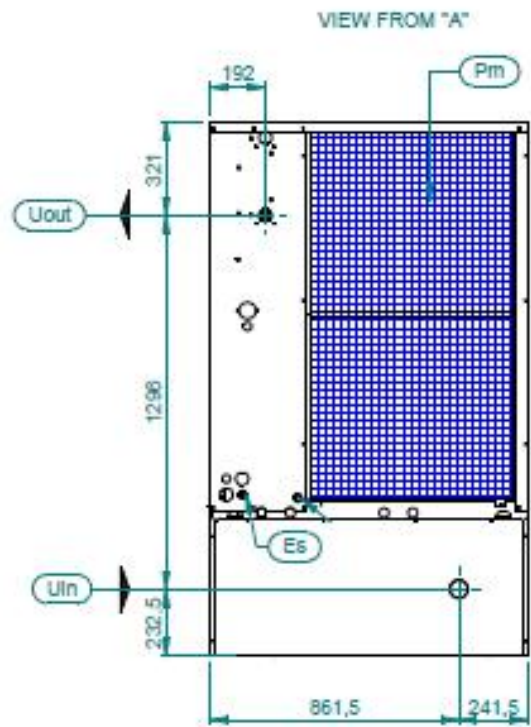
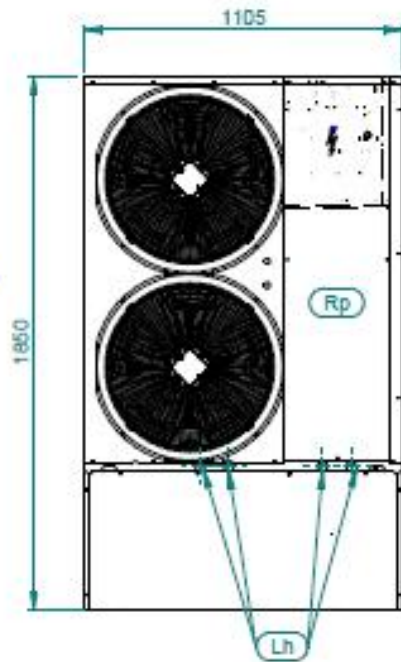
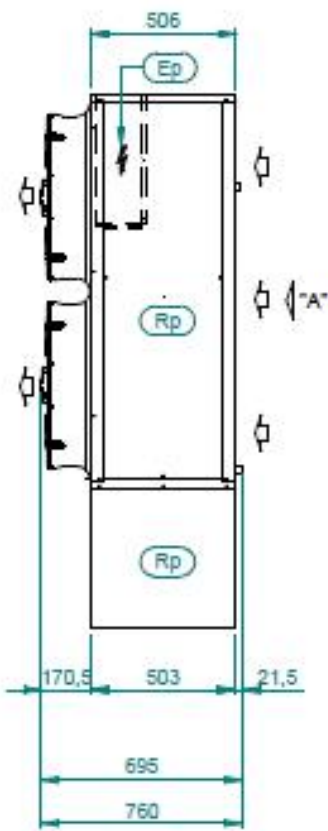

UIn	Uout
G 1" 1/4 F	G 1" M

MODEL	WEIGHT(kg)	OPERATING WEIGHT (kg)	G1 (kg)	G2 (kg)	G3 (kg)	G4 (kg)
EPSILON REV 21 CH_1PS	342	477	112	67	111	187
EPSILON REV 25 CH_1PS	353	488	116	67	112	193
EPSILON REV 28 CH_1PS	356	491	118	68	111	194

Note: These drawings are not contractually binding. For the installation design, refer to the specific dimensional drawing available on request.

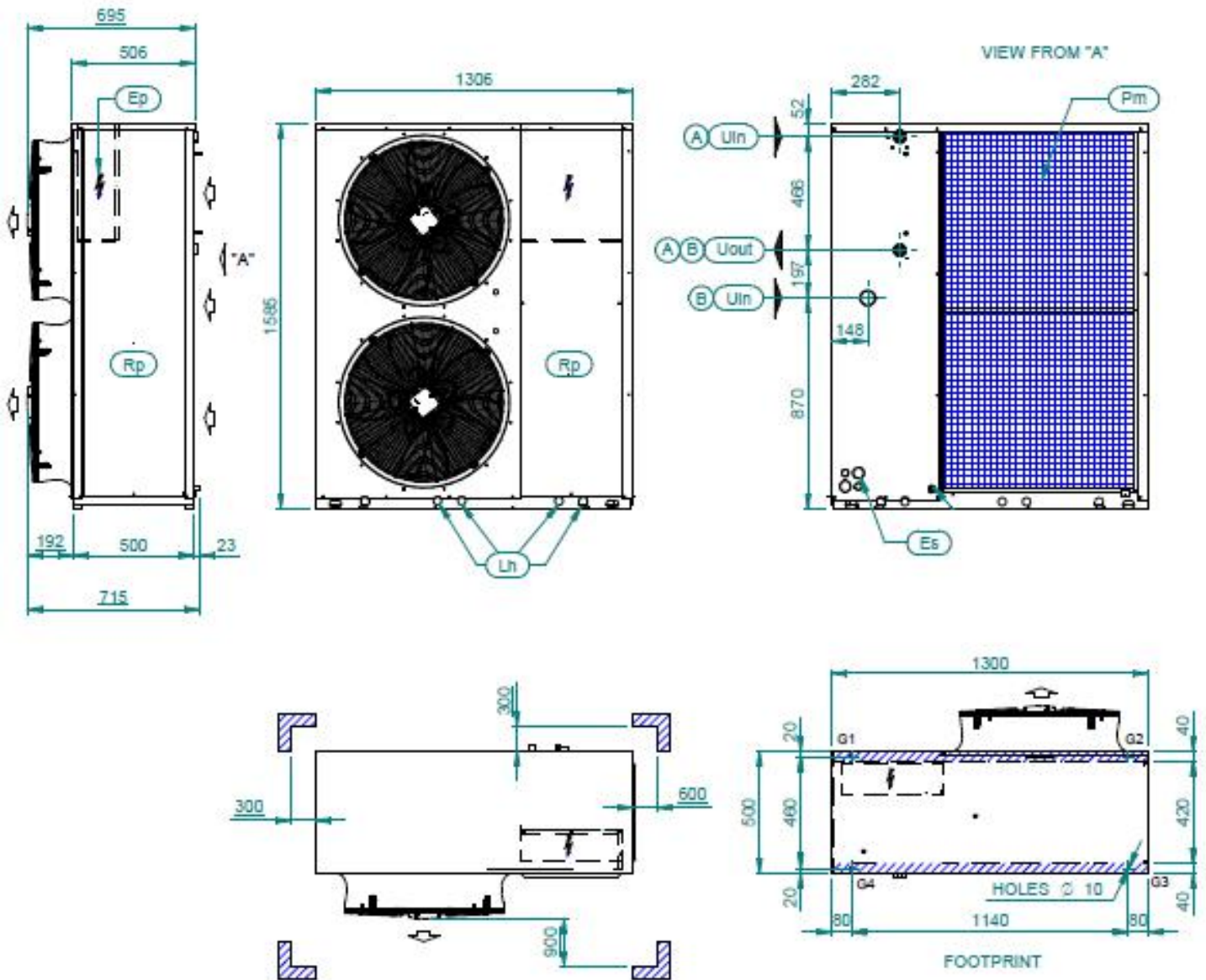

HYDRAULIC CONNECTIONS

- (A) WITHOUT HYDRAULIC MODULE
- (B) HYDRAULIC MODULE ST1P

U _{in}		U _{out}
A	B	A - B
G1"1/4 M	G1"1/4 F	G1"1/4 M

MODEL	WEIGHT(kg)	OPERATING WEIGHT (kg)				
		G1 (kg)	G2 (kg)	G3 (kg)	G4 (kg)	
EPSILON REV 31 CH	296	298	76	40	62	120
EPSILON REV 37 CH	301	303	78	40	63	122
EPSILON REV 31 CH_1P	319	323	90	42	61	130
EPSILON REV 37 CH_1P	323	327	91	42	62	132

Note: These drawings are not contractually binding. For the installation design, refer to the specific dimensional drawing available on request.

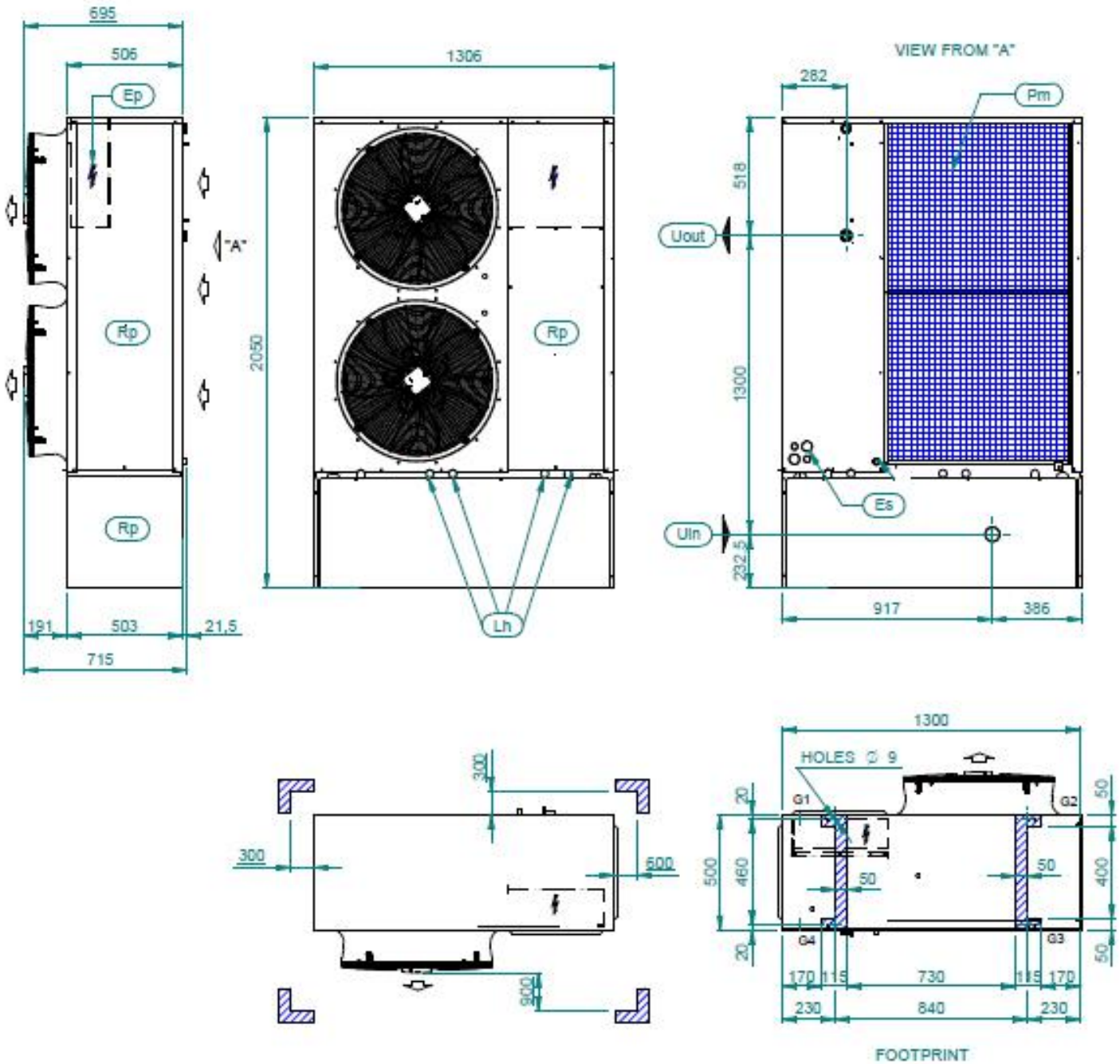

Uin	Uout
G1 1/4 F	G1 1/4 M

MODEL	WEIGHT(kg)	OPERATING WEIGHT (kg)				
		G1 (kg)	G2 (kg)	G3 (kg)	G4 (kg)	
EPSILON REV31 CH_1PS	408	543	148	82	111	202
EPSILON REV37 CH_1PS	411	546	149	82	111	204

Note: These drawings are not contractually binding. For the installation design, refer to the specific dimensional drawing available on request.

Blue Box Group S.r.l.

Via Valletta, 5 - 30010

Cantarana di Cona, (VE) Italy - T. +39 0426 921111 - F. +39 0426 302222

www.blueboxcooling.com - info@bluebox.it



Blue Box Group S.r.l. a socio unico - P.IVA 02481290282

Company directed and coordinated by Investment Latour (Sweden)